

EZA.../1



EZG.../1



**Technische Ausführung / Exécution technique / Technical specification**

Gehäuse:	Aluminiumguss
Carter:	Fonte d'aluminium
Housing:	Cast-aluminium
Lagerung:	Kugellager
Paliers:	Roulement à billes
Bearings:	Ball
Schnecken:	Stahl gehärtet und geschliffen
Vis sans fin:	Acier trempé et rectifié
Worm:	Steel hardened and ground
Schmierung:	Öl / Fett
Lubrification:	Huile / Graisse
Lubrication:	Oil / Grease
Achsdistanz:	
Entraxe:	25–90 mm
Centre distance:	

Übersetzungen / Réductions / Ratios													M max bei 1500	Motor IEC
Typ	AD	i:												
25	25 mm	4	7	9.66	15	19.5	30	39	50	60			19 Nm	56
30	30 mm	7	10	15	19.5	31	39	50	63	76	100		21 Nm	56
40	40 mm	5	7.4	10	15	19.5	30	40	50	63	79	97	45 Nm	63
50	50 mm	5	7.5	10.3	15.5	19	30	38	50	61	77	97	70 Nm	63 / 71 / 80
63	63 mm	5.4	7.5	10	15	19.5	30	40	50	60	80	100	118 Nm	80
75	75 mm	7.5	10	14.5	20	29	40	49	61	80	98		196 Nm	80 / 90
90	90 mm	7.5	10.3	15	20	31	41	52	65	84	98		310 Nm	90 / 100

**EZA**

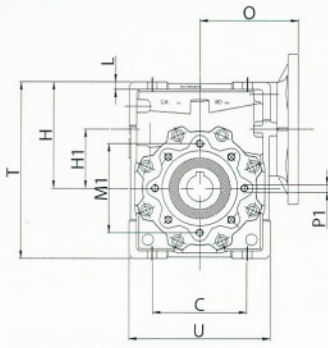

**EZG**

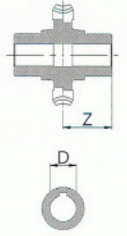
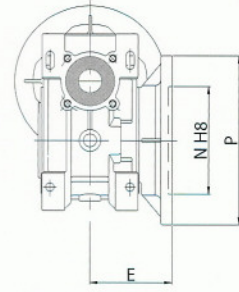
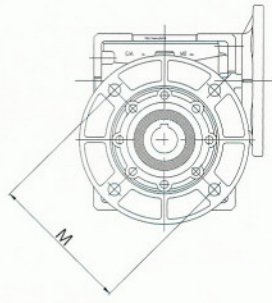
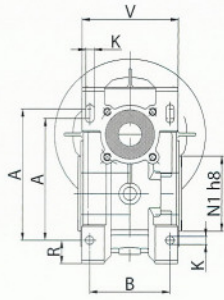

Änderungen vorbehalten  
 Modifications réservées  
 Modifications reserved

**Abmessungen / Dimensions / Dimensions**

Größe Grandeur Size	EZG															EZA					
	A	B	C	D	E	H	H <sub>i</sub>	K	L	O	R	T	U	V	Z	P	M	N	P1	M1	N1
25	-	40	45	11	-	50	25	-	-	48	-	80	68	53	53	-	-	-	3x6	-	-
30	65	50	55	14	66	55	30	6,5	7	66	15	95	85	60	31	80	68	50	4xM5	70	62
40	95/90	66/60	70	19	70,5	78	40	7	6,5	76	20	133	110	82	42	120	100	80	4xM6	75	55
50	104/105	70/75	80/75	25	90	88	50	8,5	7	83	22,5	148	120	90	46	160	130	110	4xM8	85	70
63	130/140	85	100/102	28	87	113	63	9	8	104,5	24	188	150	102	52	180	150	115	8xM8	95	80
75	150,5/157,5	90	118/126	30	88	125	75	11	10	117,5	25	210	170	110	56	200	165	130	8xM8	110	90
90	172	100	140	35	107	145	90	13	11	138	30	245	200	130	66	210	175	152	8xM10	130	110

